



SCHOTT
glass made of ideas

syriQ®

Glass Prefillable Syringes

SCHOTT is a leading international technology group in the areas of specialty glass and glass-ceramics. With more than 130 years of outstanding development, materials and technology expertise we offer a broad portfolio of high-quality products and intelligent solutions that contribute to our customers' success.

SCHOTT Pharmaceutical Systems is one of the world's leading suppliers of primary packaging and specialized analytical lab services for the pharmaceutical industry. We provide our customers quality solutions while meeting their highest demands with our expertise and broad product portfolio; including ampoules, cartridges, vials and syringes made of glass and COC polymer. Our state-of-the-art production facilities and our products comply with the highest international quality standards for pharmaceutical needs.

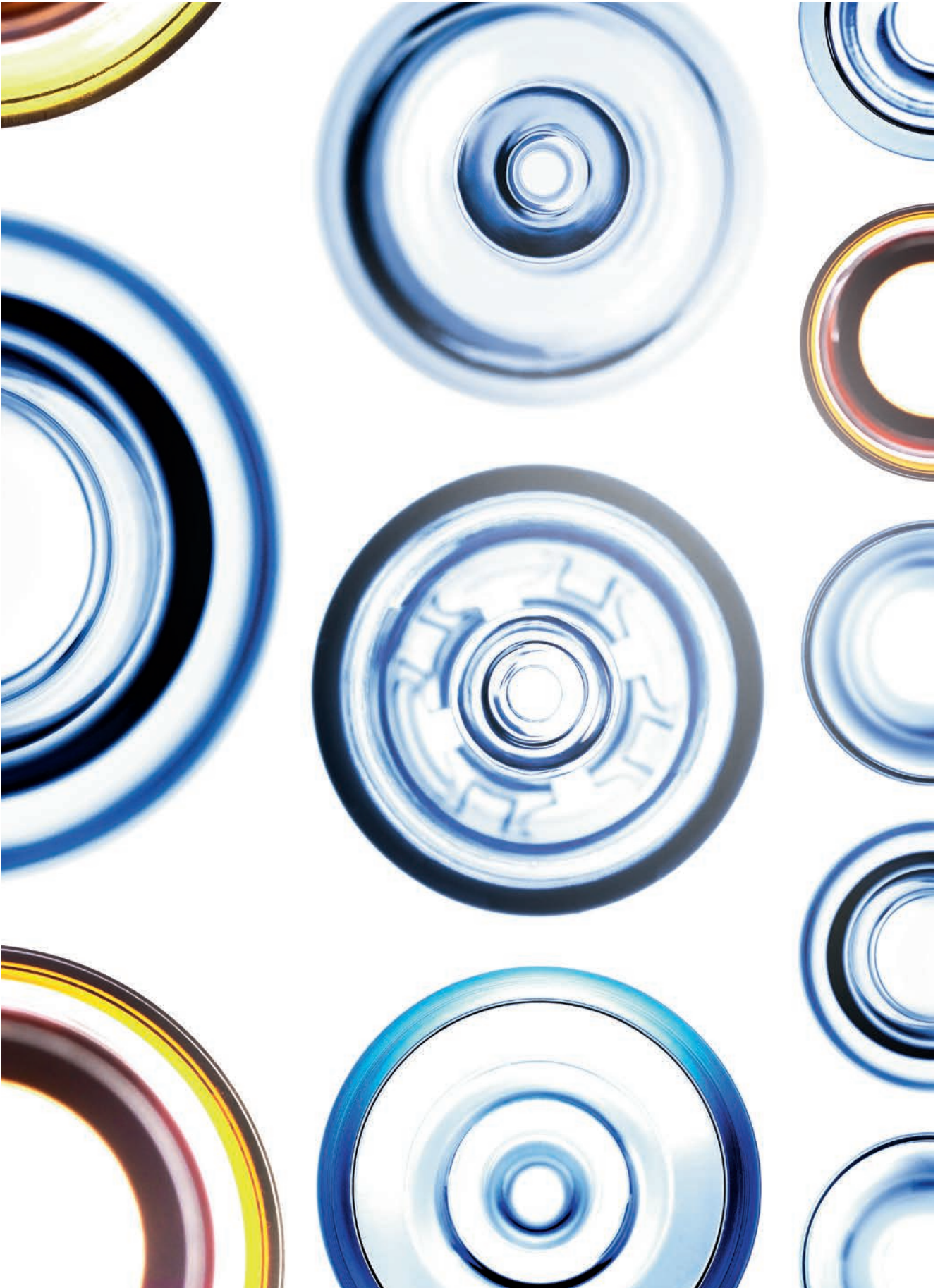

Perfect Integration

Perfect Integration is how we believe we can make a difference to your business. With SCHOTT, you not only get customised products and solutions, but a partner you can trust. A forward thinking team of professionals from R&D to sales, all working together closely with



you, strive for converting decades of research and investment into sustainable and successful pharmaceutical products. In short: Perfect Integration is our belief, our way forward, to empower your success.



Contents

- 8–9 FIOLEX® – High Quality Tubing for Pharmaceutical Packaging
- 10–21 Broad Product Portfolio
- 22–23 Benefits of syriQ® – Expertise Perfectly Integrated in Your Product
- 24–25 Our Manufacturing Process – A Clear Commitment to High Quality
- 26–27 Compliance with International Norms
- 28–29 SCHOTT – Your Partner throughout the Drug Life Cycle





FIOLAX® – High Quality Tubing for Pharmaceutical Packaging

FIOLAX® – The first choice for pharmaceutical packaging

Glass has many advantages over other packaging materials used for pharmaceutical primary packaging. Otto Schott, founder of the present-day SCHOTT AG, was far ahead of his time when he introduced FIOLAX® tubing in 1911 for pharmaceutical packaging. Since then, FIOLAX® has become a synonym for premium glass for the first hydrolytic class.

This special glass is known for its outstanding chemical resistance, neutrality, impermeability, and strength. Containers made out of FIOLAX® are perfect for the storage and delivery of a wide range of injectable drugs including sensitive biotech drugs. This excellent raw material is the starting point for perfect pharmaceutical packaging containers or systems like prefillable syringes (PFS).

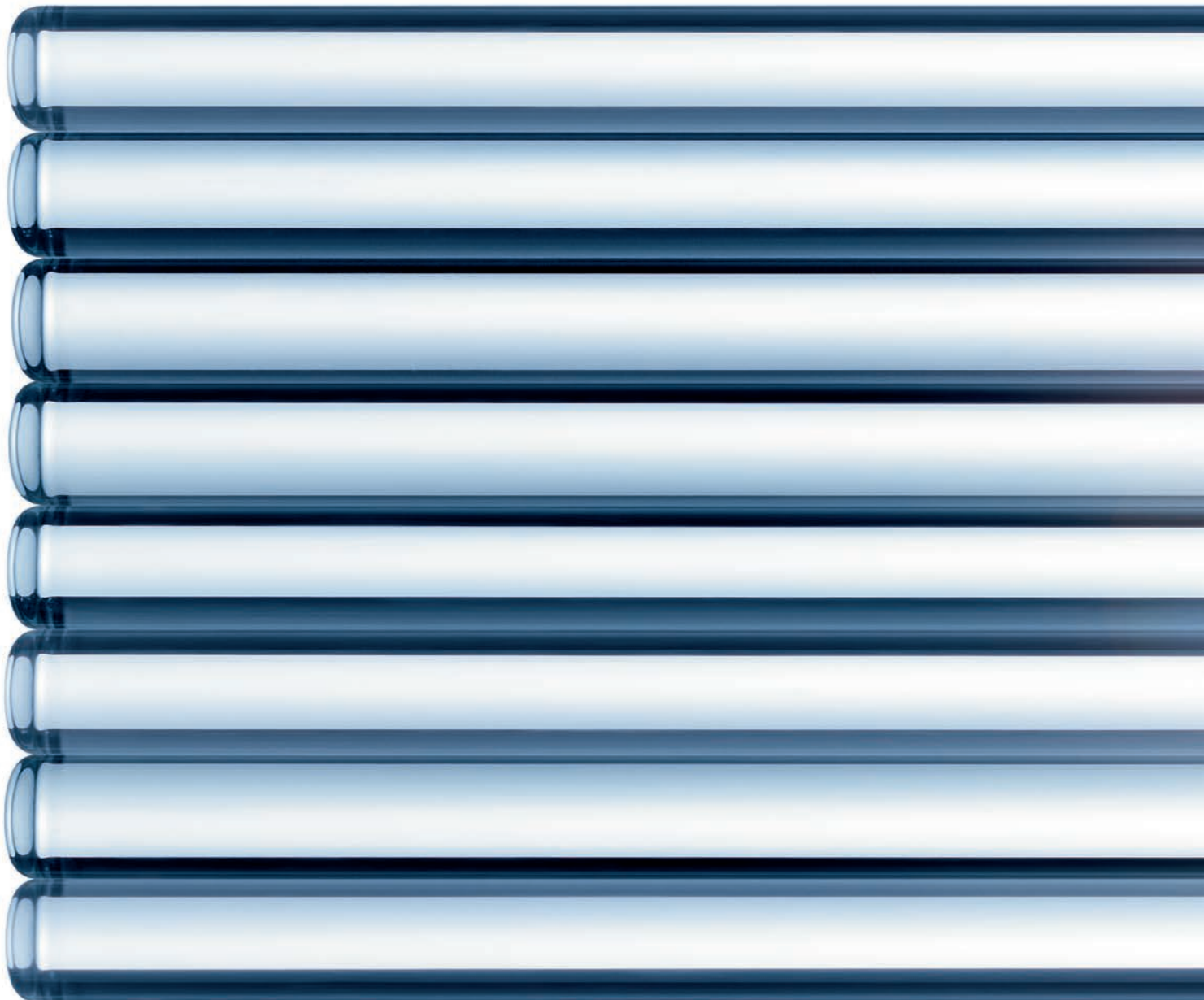

FIOLAX® – Perfect for PFS

The narrow geometrical tolerance typical of FIOLAX® tubing is an excellent raw material for high-quality glass PFS. The precise dimensions of the tubing are critical for the forming of Luer Cone, fluid path, or the flange of a syringe. The narrow inner diameter tolerance of up to ± 0.05 mm also ensures plunger tightness and consistent gliding forces. This is also critical for accurate filling especially for syringe barrels with graduation.

syriQ® – High-quality glass PFS from SCHOTT

All our glass PFS are made of premium-quality SCHOTT FIOLAX® tubing. Our proven expertise in glass technology and converting in combination with continuous research and development enable us to provide superior PFS.

Broad Product Portfolio

syriQ[®] – Suitable for Various Applications

The changing dynamics in the global pharmaceutical industry are creating an increased demand for drug delivery systems that are patient-friendly and cost-effective. PFS from SCHOTT provide pharmaceutical manufacturers, health-care providers, and patients with several benefits. These benefits include patient compliance, reduction of dosing errors, minimized risk of contamination, and the promotion of safe injections.

Anti-thrombotic



Vaccines



Our approach

We partner with you to design, develop, and manufacture high-quality PFS solutions that meet your specific needs.

syriQ® PFS are designed and developed to meet the stringent and changing needs of the pharmaceutical, cosmetics, and biotech industries. At SCHOTT we understand the challenges associated with the PFS and also the requirements for a PFS for various therapeutic areas such as anti-thrombotic, vaccines, biotech, and special applications.

We offer customized PFS solutions for these applications considering critical aspects like

- Drug stability
- Easy integration and processing on filling lines
- Compatibility with safety devices and autoinjectors
- Safety and convenience for the end users

Biotech



Special applications



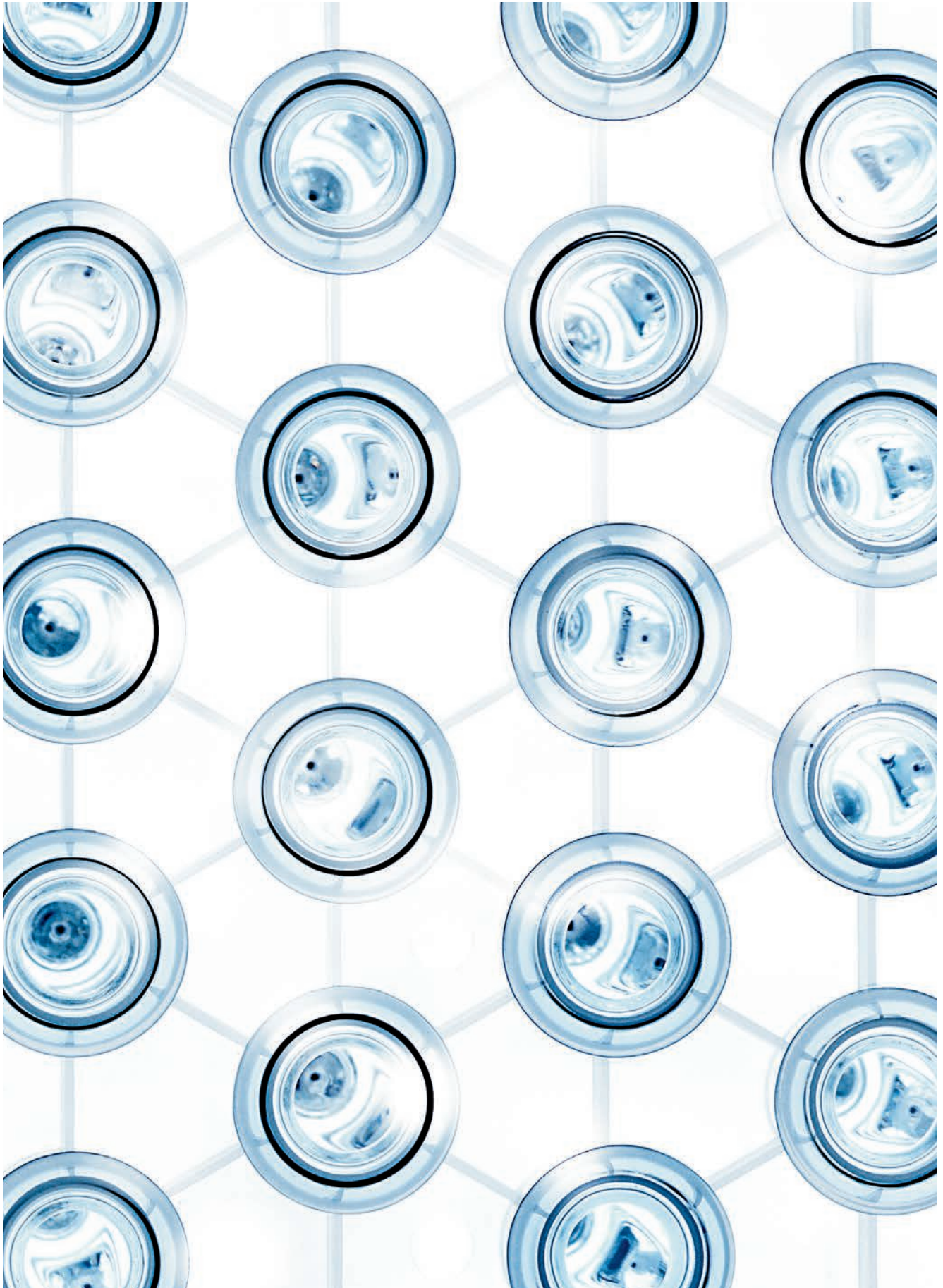

syriQ® – A Comprehensive Portfolio

SCHOTT offers a broad portfolio of glass PFS

- Sizes from 0.5 ml to 3 ml
- Staked needle, Luer Cone, Luer Lock, Luer Lock with V-OVS®*
- Cut flange or round flange
- Printing or graduation available
- Other formats are available on demand
- Available as bulk or sterile

SCHOTT's high-quality syringe barrels are produced on fully automated, high-speed precision forming lines. Rigorous product inspection and strict process control is ensured by state-of-the-art camera inspection for both dimensional and cosmetic aspects.



syriQ® bulk

syriQ® bulk syringe barrels are packed in trays and are available for integrated washing, sterilization, siliconization, and filling at your facility.

syriQ® sterile

syriQ® sterile PFS are delivered ready for the filling process. They are washed, siliconized, and assembled with a tip closure or a needle shield. These glass syringes are manufactured on fully automated production lines (forming, needle staking, washing, siliconization, closure assembly, and packaging). They are packed in a nest which is placed into a tub. The tub is covered with a Tyvek®** inlay, placed in the tub followed by a Tyvek®** seal. After being packed in header bags, the tubs are sterilized.

Syringe components

SCHOTT syriQ® syringes are available as a complete system including components such as plungers and plunger rods according to the customer's requirements.



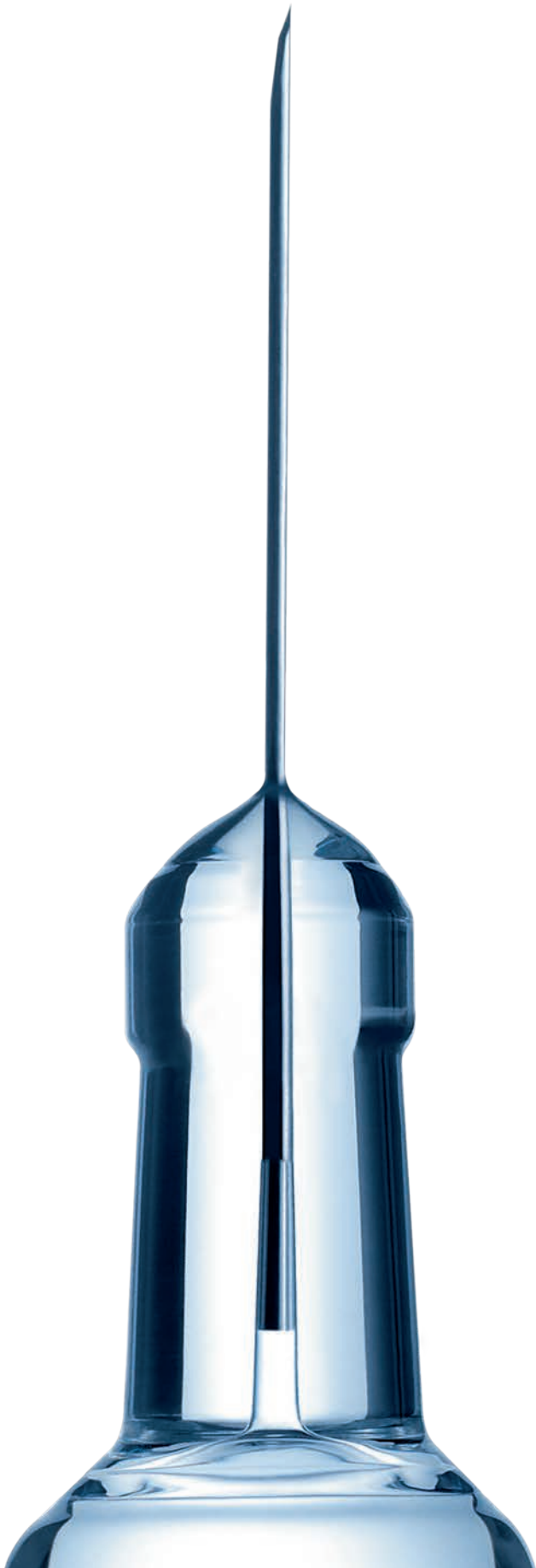

syriQ® SN
Formats: 0.5 to 2.25 ml

syriQ® Staked Needle Syringes

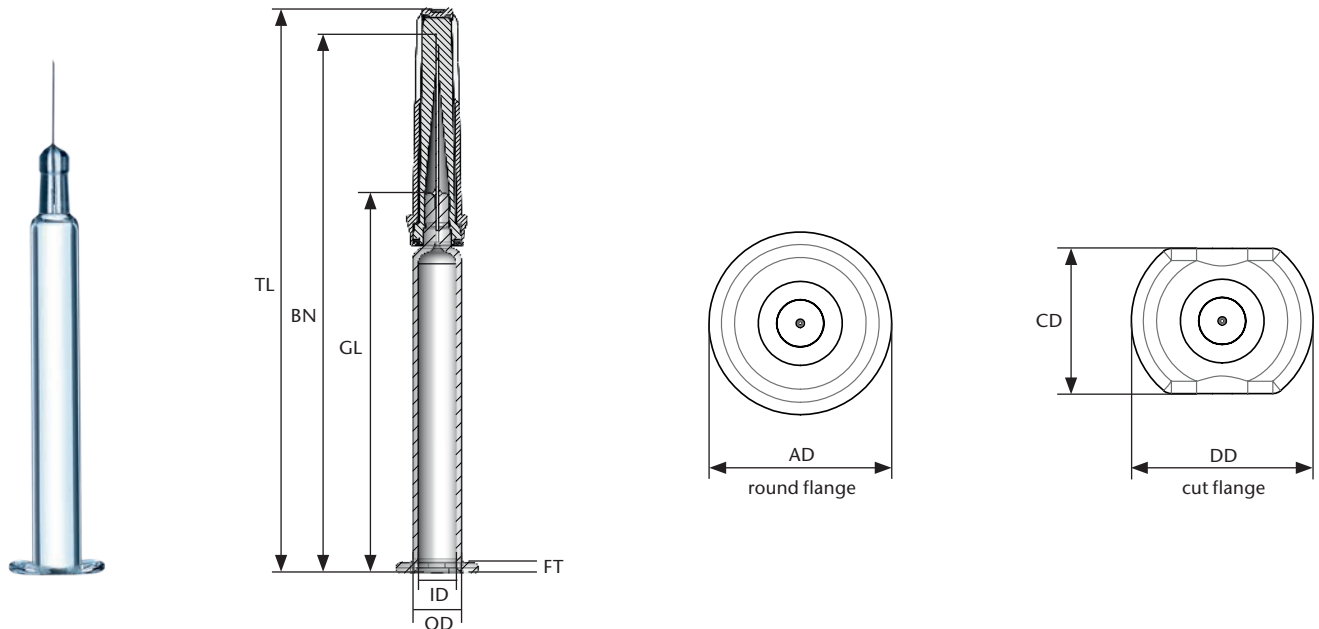

Format in mm	Total Length (TL)	Barrel/Needle (BN)	Glass Barrel (GL)	Inside Diameter (ID)	Outside Diameter (OD)	Flange Thickness (FT)	Flange (DD)	Flange (CD)	Flange (AD)	
0.5 ml 25G	1/2"	74.6	70.2	57.5	Ø 4.65	Ø 6.85	1.8	Ø 13.4	Ø 10.5	Ø 13.4
1.0 ml long 22-29G	1/2"	80.9	76.7	64.0	Ø 6.35	Ø 8.15	1.9	Ø 13.8	Ø 11.0	Ø 13.8
	5/8"	85.7	79.9	64.0	Ø 6.35	Ø 8.15	1.9	Ø 13.8	Ø 11.0	Ø 13.8
1.0 ml short 25G	5/8"	68.7	64.1	46.7	Ø 8.65	Ø 10.85	2.2	Ø 17.75	Ø 14.7	Ø 17.75
2.25 ml 27G	1/2"	82.5	78.1	54.4	Ø 8.65	Ø 10.85	2.2	Ø 17.75	Ø 14.7	Ø 17.75

			22G	25G	27G	29G
	RNS	 Aptar Stelmi RNS 4800				
	FNS	 Aptar Stelmi NS 4800GS Dätwyler FM27 West 7028/55 grey				

- All barrels made out of FIOLAX®
- All formats also available as syriQ® bulk
- Needles available with different bevel designs on request
- Other needle shields on request
- Plungers from Aptar Stelmi, Dätwyler, and West
- Plunger rods out of polypropylene
- Graduation or dose marks available on request



syriQ® LLA
Formats: 1.0 to 3.0 ml

syriQ[®] Luer Lock Adapter Syringes

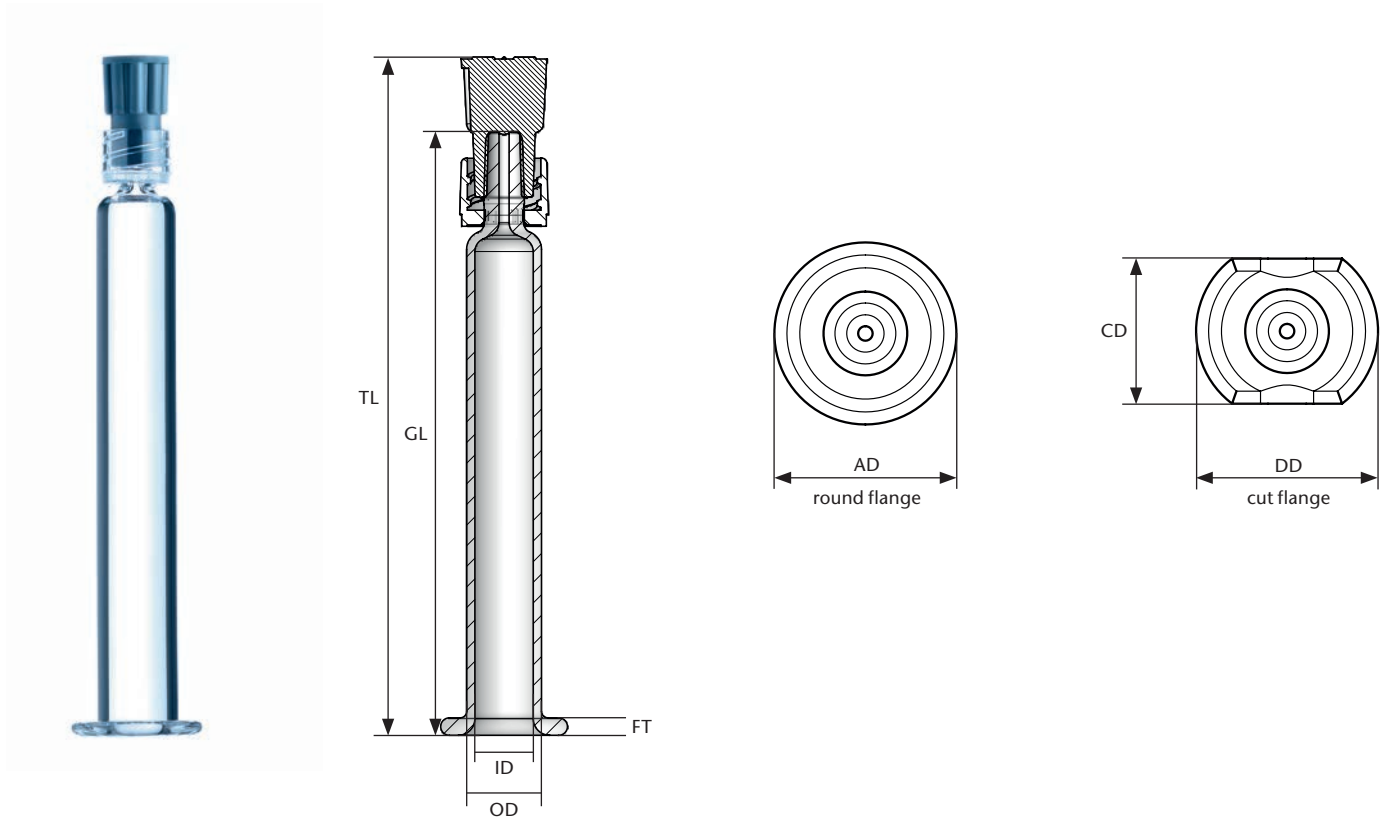

Format in mm	Total Length (TL)	Glass Barrel (GL)	Inside Diameter (ID)	Outside Diameter (OD)	Flange Thickness (FT)	Flange (DD)	Flange (CD)	Flange (AD)
1.0 ml long	73.8	65.7	Ø 6.35	Ø 8.15	1.9	Ø 13.8	Ø 11.0	Ø 13.8
3.0 ml	92.6	84.7	Ø 8.65	Ø 10.85	2.2	Ø 17.75	Ø 14.7	Ø 17.75



- All barrels made out of FIOLAX[®]
- All formats also available as syriQ[®] bulk
- Graduation or dose marks available on request
- Further rubber formulation for tip cap on request
- Plungers from Aptar Stelmi, Dätwyler, and West
- Plunger rods out of polypropylene



syriQ® LL OVS®
Formats: 1.0 to 3.0 ml

syriQ[®] Luer Lock OVS[®] Syringes

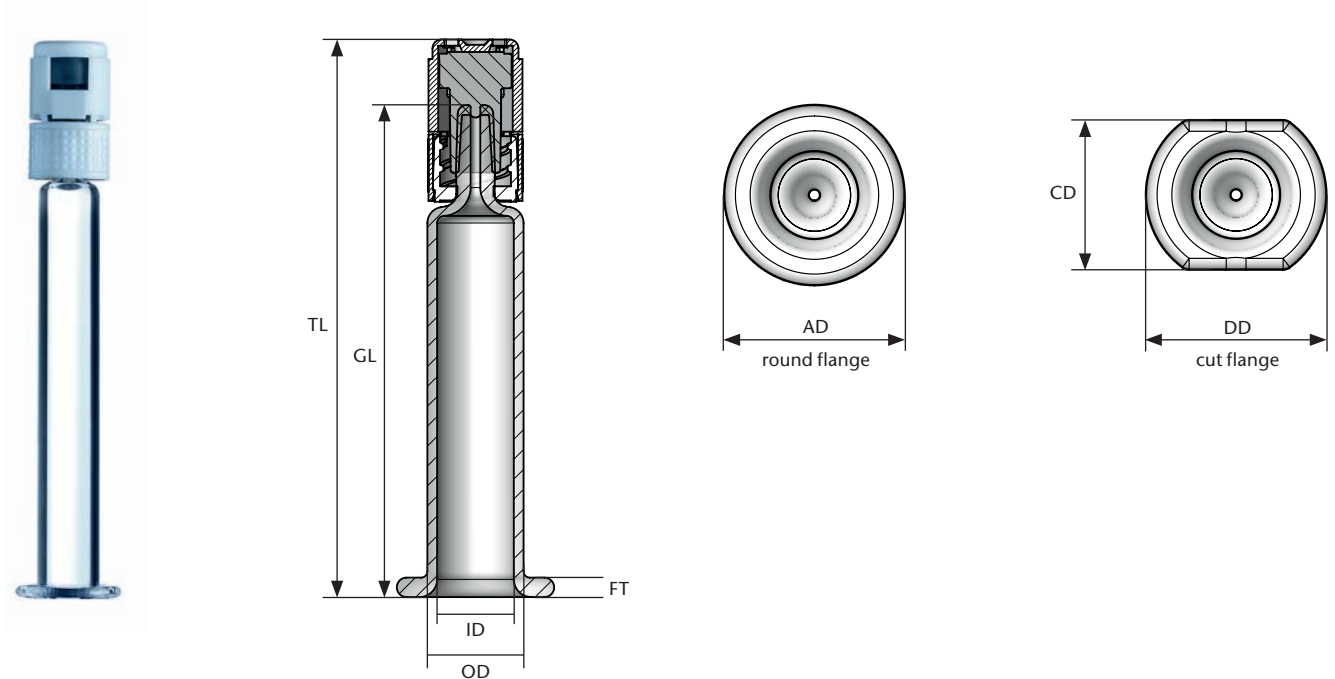

Format in mm	Total Length (TL)	Glass Barrel (GL)	Inside Diameter (ID)	Outside Diameter (OD)	Flange Thickness (FT)	Flange (DD)	Flange (CD)	Flange (AD)
1.0 ml long	73.9	65.7	Ø 6.35	Ø 8.15	1.9	Ø 13.8	Ø 11.0	Ø 13.8
3.0 ml	92.4	84.3	Ø 8.65	Ø 10.85	2.2	Ø 17.75	Ø 14.7	Ø 17.75



- All barrels made out of FIOLAX[®]
- All formats also available as syriQ[®] bulk
- Graduation or dose marks available on request
- Plungers from Aptar Stelmi, Dätwyler, and West
- Plunger rods out of polypropylene



syriQ® LC
Formats: 1.0 to 3.0 ml

syriQ® Luer Cone Syringes

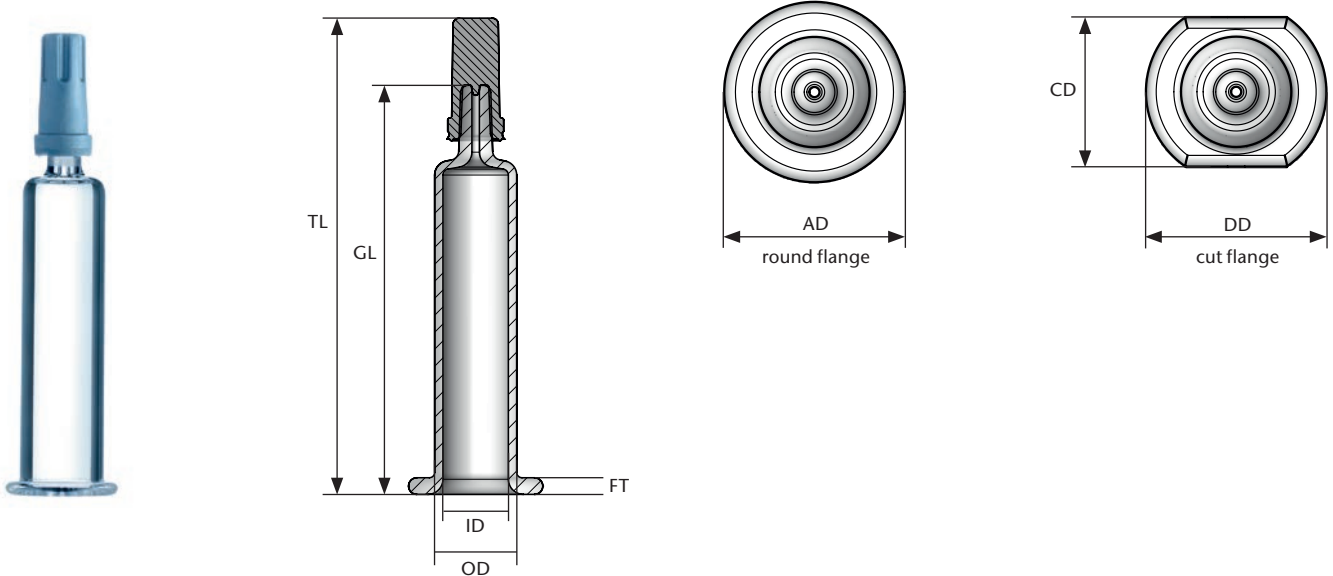

Format in mm	Total Length (TL)	Glass Barrel (GL)	Inside Diameter (ID)	Outside Diameter (OD)	Flange Thickness (FT)	Flange (DD)	Flange (CD)	Flange (AD)
1.0 ml long	73.6	64.7	Ø 6.35	Ø 8.15	1.9	Ø 13.8	Ø 11.0	Ø 13.8
1.0 ml short	55.6	46.7	Ø 8.65	Ø 10.85	2.2	Ø 17.75	Ø 14.7	Ø 17.75
1.25 ml	60.4	51.5	Ø 8.65	Ø 10.85	2.2	Ø 17.75	Ø 14.7	Ø 17.75
2.25 ml	74.4	65.5	Ø 8.65	Ø 10.85	2.2	Ø 17.75	Ø 14.7	Ø 17.75
3.0 ml	92.2	83.3	Ø 8.65	Ø 10.85	2.2	Ø 17.75	Ø 14.7	Ø 17.75



- All barrels made out of FIOLEX®
- All formats also available as syriQ® bulk
- Graduation or dose marks available on request
- Further rubber formulation for tip cap on request (validation needed)
- Ceramic color-based cone coating or grinded cone tip on request
- Plungers from Aptar Stelmi, Dätwyler, and West
- Plunger rods out of polypropylene

Benefits of syriQ® – Expertise Perfectly Integrated in Your Product



Tight dimensional tolerance for accurate filling and functionality

- High-quality SCHOTT FIOLAX® tubing
- Precise forming with high process capability and stability
- 100% camera control for dimensional aspects

Low particle and low contamination

- Optimized cutting
- Controlled environment
- Optimized handling of the syringes

Needle with superior performance

Our sophisticated needle gluing process, coupled with in-line camera inspection, results in:

- Strong bonding of needle and barrel
- Needle sharpness: process is optimized to avoid needle hooks
- Needle angularity: precise positioning of the needle inside the needle shield

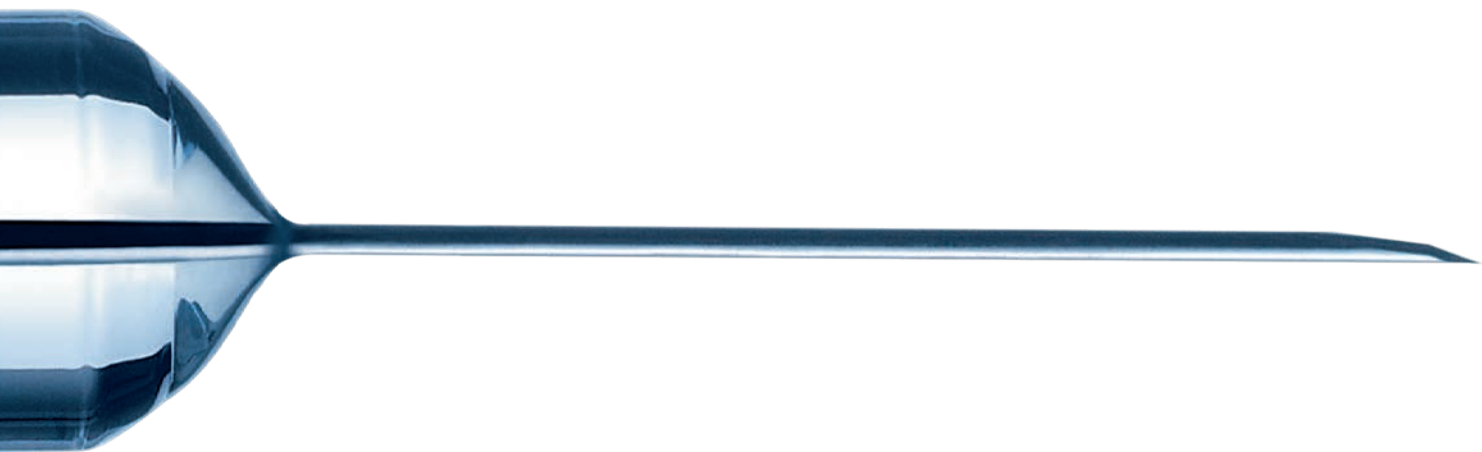
**Excellent gliding performance**

With our experience and capability to control the siliconization process we can customize the silicone profile to meet your requirements.

Low cosmetic defects

Handling process with no glass-to-glass contact and the in-line camera inspection greatly reduce cosmetic defects like scratches, dirt, particles, and cracks. This means less rejections on your filling line.

Easy integration

Our tub and nest design is optimized for easy integration in the filling lines.

Customization

We offer customized PFS solutions to meet your drug delivery needs as well as the needs of patients.

Our Manufacturing Process – A Clear Commitment to High Quality

SCHOTT glass syringes are manufactured on state-of-the-art production lines with highly stable and validated processes. Permanent process optimization by Six Sigma principles and continuous training of employees help to maintain the highest quality levels. Throughout the process handling of the syringe is optimized to reduce glass-to-glass contact, resulting in syringes with high mechanical strength and low cosmetic defects.

Clean room ISO 6

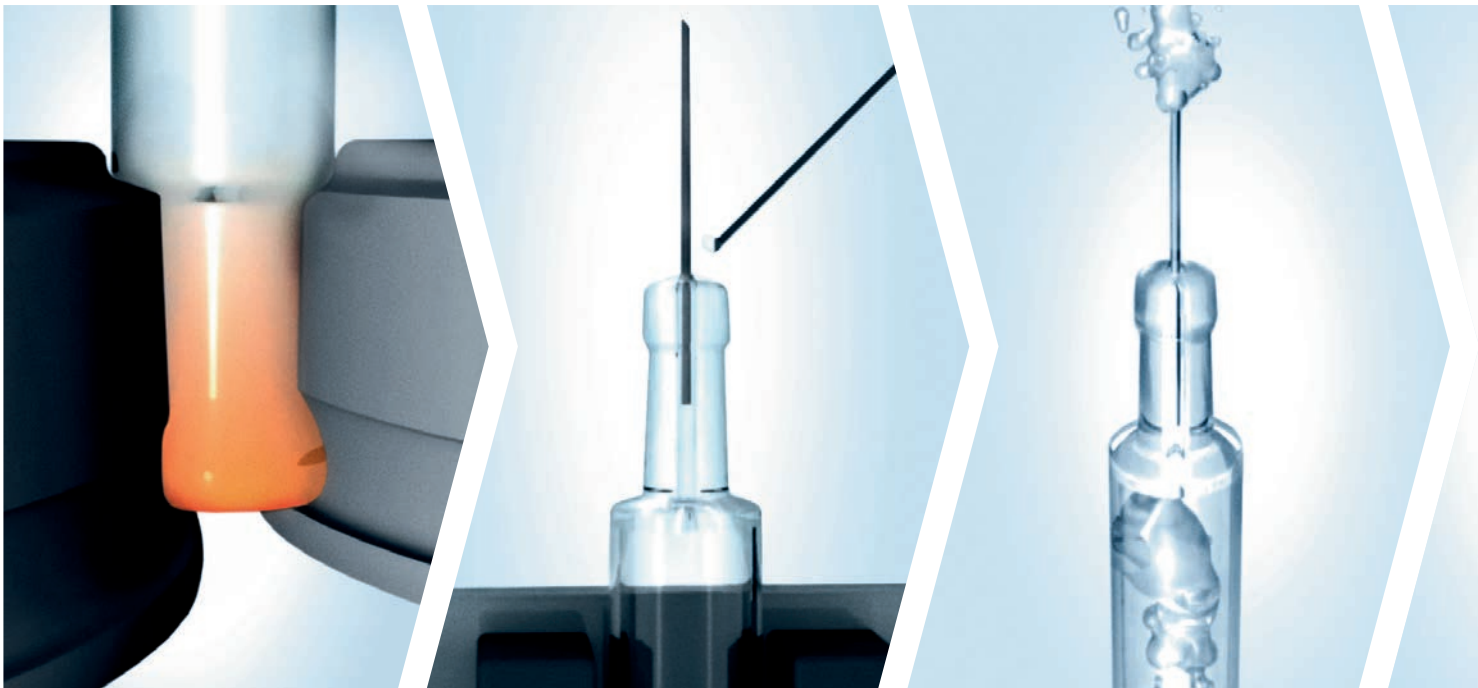

Forming

Tubes are loaded into the forming machine with an automatic tube loader. The tubes are formed with precise forming tools. The syringe barrel is separated from the tube and the flange is formed. All syringe barrels are controlled by a camera system for both dimensional and cosmetic aspects. In addition, the syringe barrels can be printed or cone coated for Luer Cone syringes.

Needle assembly

The needle is placed into the Luer channel. Glue is then applied and cured with a UV lamp. In-line camera control and IPC ensures excellent quality of needles and needle bonding.

WFI washing

The syringes are washed with WFI and dried, which eliminates contamination.

Clean room ISO 7



Siliconization

Syringe barrels are siliconized with state-of-the-art equipment like diving nozzles. This ensures the precise dosage of silicone and the homogenous distribution of silicone oil inside the barrel.

Closure setting

After the siliconization an appropriate closure, e.g. tip cap, OVS®, rigid or flexible needle shield, is placed on the syringe in order to ensure closure tightness.

Packaging

The syringes are placed in a nest and the filled nests are placed into a tub. A protective Tyvek® inlay is placed in the tub followed by a Tyvek® seal to build a barrier against microbial contamination. The sealed tubs are covered with a Tyvek® bag. Then they are visually inspected, packed into boxes and pallets, and sent for sterilization.

Compliance with International Norms: Quality that Exceeds Standard Requirements

The quality of syriQ® PFS starts with:

- Fully automated production lines
- cGMP and continuous training of personnel according to strict production process guidelines
- Reliable quality systems and rigid quality controls for consistent high-quality
- State-of-the-art camera systems for dimensional and cosmetic control
- In-process control (IPC) for compliance with specifications of barrel dimensions, cosmetic quality, and functionality



Quality management system

All syriQ® PFS are manufactured according to ISO 9001, ISO 13485, and ISO 15378. Additionally the production process is optimized with a continuous improvement program based on Six Sigma principles.

Regulatory compliance

Due to strict quality control and excellent process capability, syriQ® PFS comply with the international norms like EP, USP, and JP. SCHOTT glass syringes are filed with the FDA under DMF 9205.



SCHOTT – Your Partner throughout the Drug Life Cycle

Our dedicated cross-functional team offers advanced customer consulting services through all drug life-cycle stages in order to find optimal solutions to meet your individual needs.

Drug development

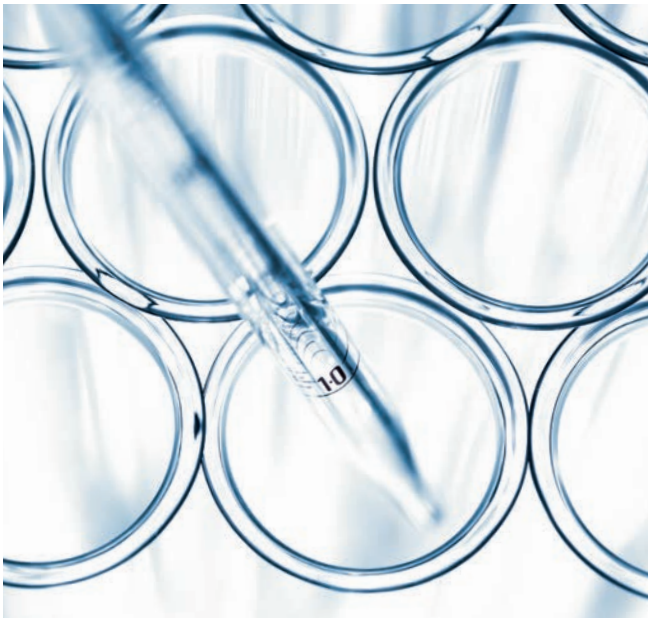

Extensive support for packaging selection:

- Customer value chain evaluation
- Technical product specifications (TPS)
- Samples from stock

Your partnership with SCHOTT starts with a quick evaluation of your value chain to understand the requirements of the drug and primary packaging. SCHOTT will provide you with all the relevant information on our syringe systems along with samples from stock and standard technical product specification (TPS). In case of special design requirements, we will support you in defining the syringe specifications and in estimating the development efforts with regard to project cost and timeline.

Regulatory support

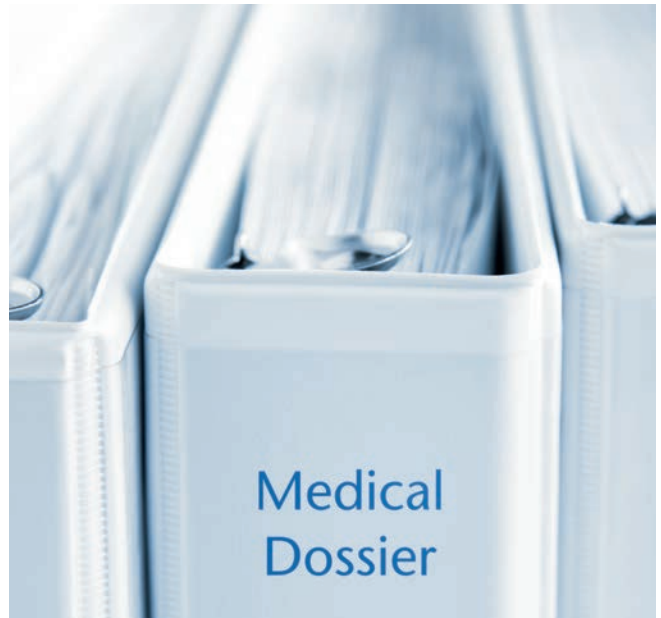

Regulatory filing facilitated by:

- Cooperative audits
- Comprehensive technical dossier
- LOA for DMF

To support your registration activities, an established TPS, technical dossier, and the Letter Of Authorization (LOA) for the Drug Master File (DMF) will be provided.

Commercial manufacturing

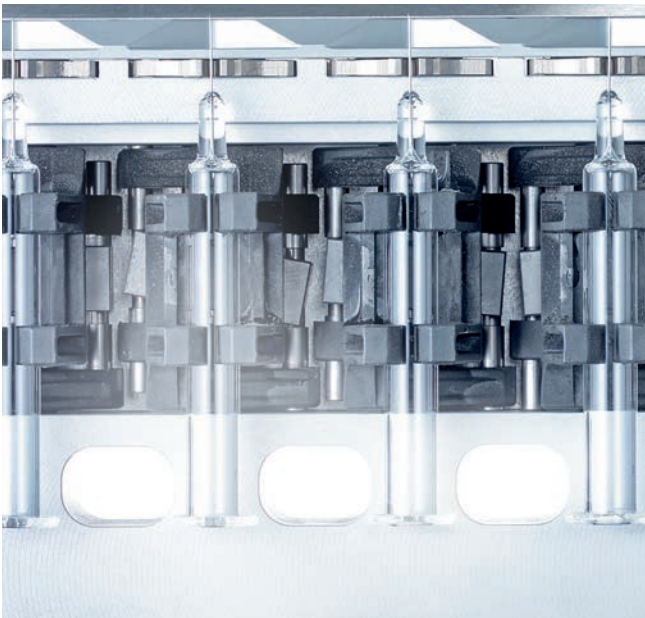

Enabling smooth operation and supply chain:

- Capacity and supply security
- Short lead times
- Competent complaint management

In the commercial phase we ensure supply security of the products through flexible and efficient supply chain management. Together, we can minimize total cost of ownership. If any issues related to quality or technical improvements should occur, our SCHOTT team including Quality Management, Process Engineering, and R&D provides a fast and reliable root cause analysis and problem solving.

Life-cycle management



Added value through innovative solutions:

- Continuous technology development
- Constant product improvement
- Product innovation

Primary packaging is seen as a differentiating factor in a competitive marketplace. Life-cycle management of existing products may involve a change of primary packaging. In such cases, a dedicated cross-functional project team is established to assess feasibility, development costs, and timeline.





Pharmaceutical Systems

SCHOTT AG

Hattenbergstrasse 10

55122 Mainz

Germany

Phone: +49 (0)6131/66-1589

Fax: +49 (0)6131/66-1916

pharmaceutical_packaging@schott.com

www.schott.com/pharmaceutical_systems