

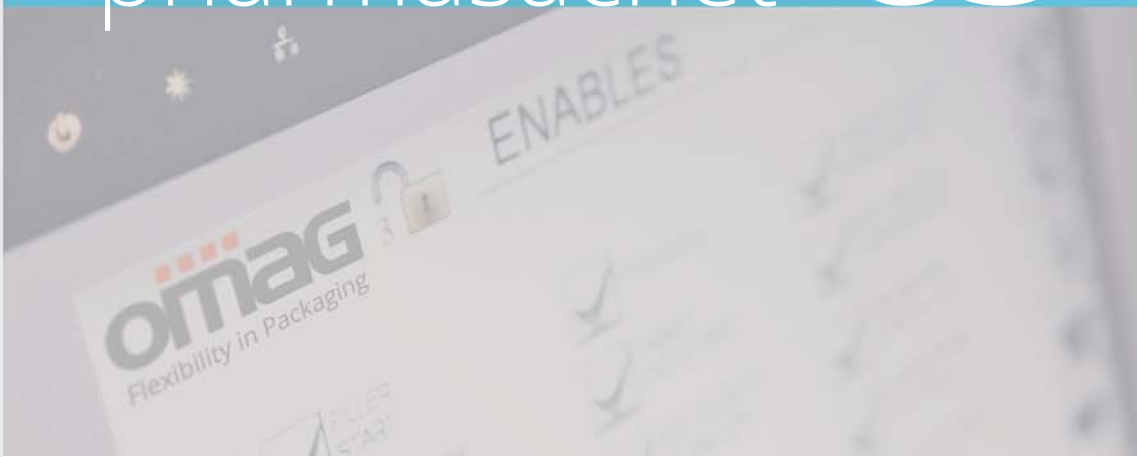

pharmasachet C3





extreme accessibility

Access to C3 equipment is amazingly easy since it is provided with a series of assembly/disassembly-assisted systems such as fillers, sealing and reel lifting groups.

Consequently accurate and user-friendly design allows operator and MTN technician to get access to any part and component without any difficulty so to implement easily any cleaning, parts replacement and control procedures.

easy cleaning

Parts in contact with product in stainless steel. Mirror polished surfaces.

Accurate design of each single detail in order to prevent any product deposit. All above features make C3 packaging machine an extremely easy equipment to clean, with negligible time consumption.

balcony and compact design

Pharmasachet Machine Mod. C3 is designed for the pharmaceutical market.

Balcony design, easy accessibility, absence of external cables, leaning outside mechanical components make the equipment fully compliant with the most stringent GMP requirements.

The lower number of components fitted on give the machine a really compact design allowing the placement in limited space.





auger dosing system

Multi-lane Auger Filler especially designed for pharmaceutical powders and products with poor flowability.

The Unit is equipped with a Pre-feeding Group for a smooth and constant feed of the product into the dosing chamber, allowing high accuracy.

All parts in contact with product are in stainless steel and mirror polished to avoid any product residue deposition.

The Filler Pharma grade Feeding Hopper is provided with a special stirring system able to avoid any phase separation of the product.

State of the Art Dosing Auger is driven by its own Brushless motor allowing fine adjustment on each lane.

Dosing Tubes Cooling System for optimal treatment of heat sensitive products.

The Dosing System can be easily removed by means of an automatic lifting device guaranteeing extreme accessibility and cleaning.

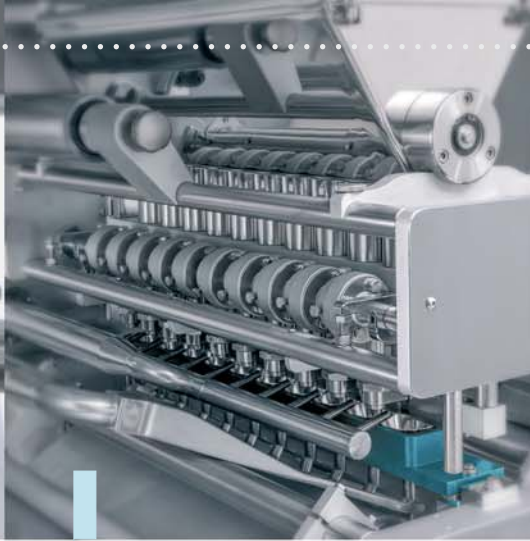

volumetric dosing system

Oscillating Dosing Cups System for free-flowing and granular products.

The Group is installed on a sliding support that allows to remove and clean it easily without using any mechanical tool.

It is designed with:
- Centralized dosing chamber adjustment;
- Single dosing cup adjustment.

All parts in contact with the product are in stainless steel and FDA approved material.

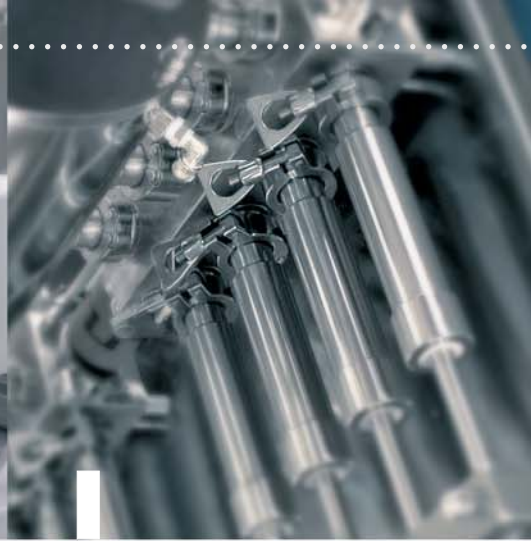

liquid/pasty dosing system

Filling System to dose liquid and pasty products.

Hopper and Dosing Tubes designed with Clamp Connection for quick disassembly and cleaning.

It is driven by Brushless Motor for fine adjustment.

CIP Equipment for assisted cleaning of the Dosing Unit.

complete sachet packaging line

Complete sachet packaging line for medium or high speed production complete with automatic feeding system Mod. S1 for sachet counting and transfer to the down-stream cartoner.



C3

Sachet continuous motion
vertical form/fill/seal
packaging machine

tablets feeding system

Feeding System for tablets,
capsules, effervescent
products and other



Sachet pick-up system, placed below
the horizontal cutting area.

Sachet positive transport
to the Counting Station.



sachet coding system

Two-axes sistem, electronically controlled, for printing head motion.

The head moves horizontally along the foil and then follows vertically the film advancement in continuous without any reel stop.

C3 can be equipped with any thermal ink-jet printer.

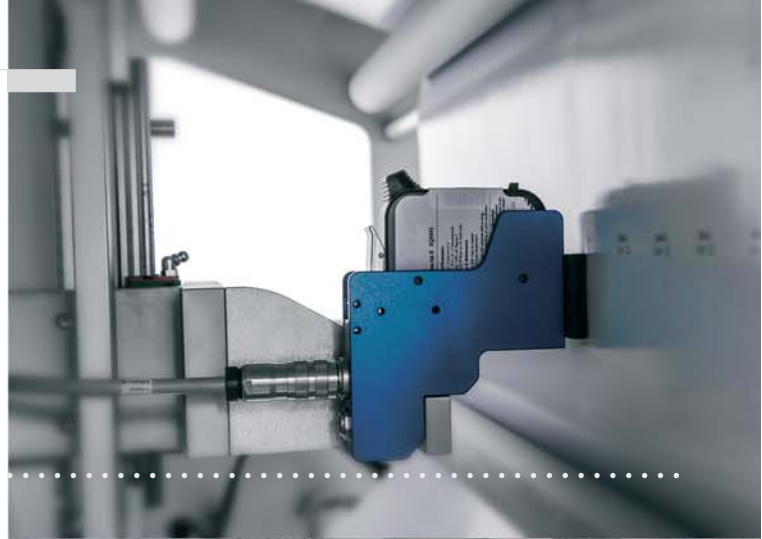

pharma-code reading of packaging substrate

Pharma code reader to detect the presence of a bar code, pharma code or datamatrix on the reel packaging film



sachet statistical weight check with feed-back signal

Special system for sachet statistical quality check. It can be equipped with check weigher, report printer or collection samples for off-line leak test.

A feed-back signal is generated and sent in presence of Auger Dosing System.

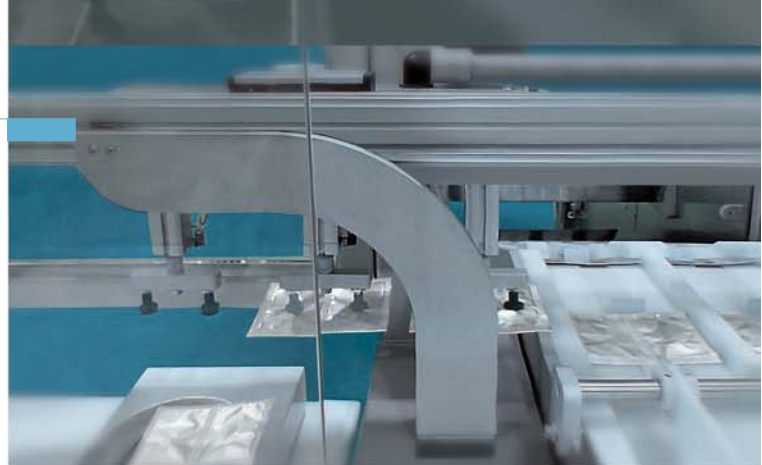

Pick-up Heads by vacuum cups and Sachet transfer system to the buckets of a cartoner.



pharmasachet c3 / specifications

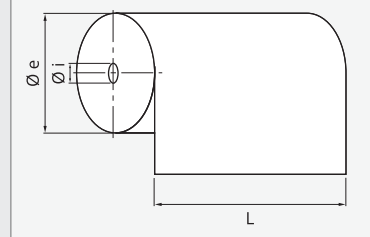
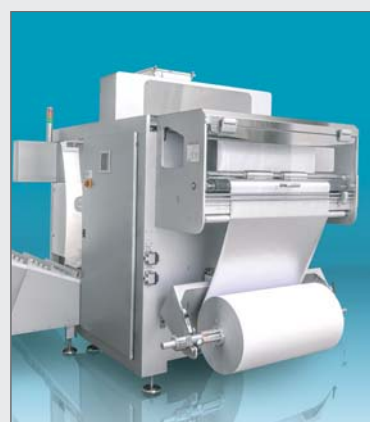
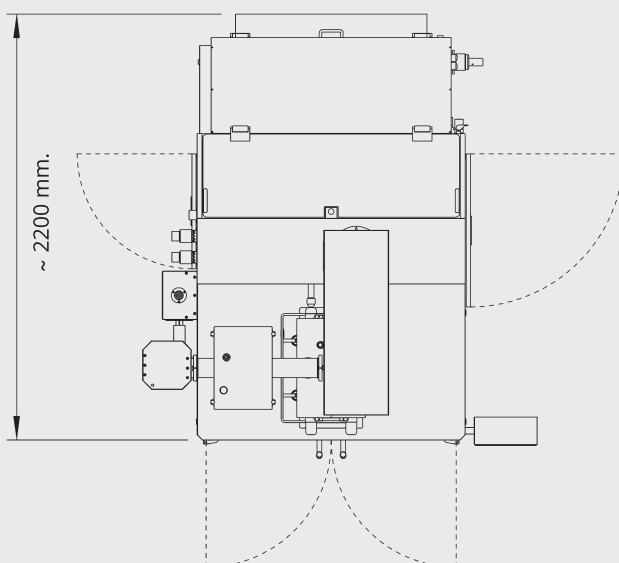
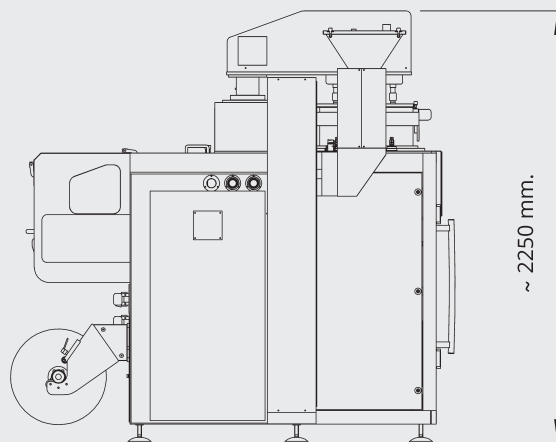
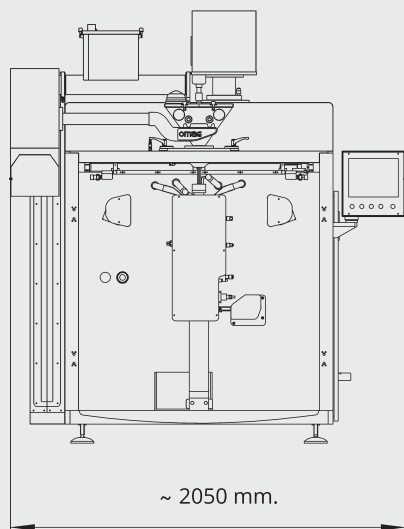

Technical data

absorbed power	~ 6 kW
air consumption	~ 250 NI/min. - 6 bar
net weight	~ 2000 kg

Reel size range

Ø e	min - max = 500 - 800 mm.
Ø i	min - max = 76 - 150 mm.
L	min - max = 600 - 1200 mm.

OMAG reserves the right to update, change, modify or otherwise alter technical features and descriptions reported in this brochure at any time, based on future technical innovations and markets evolving requirements.