

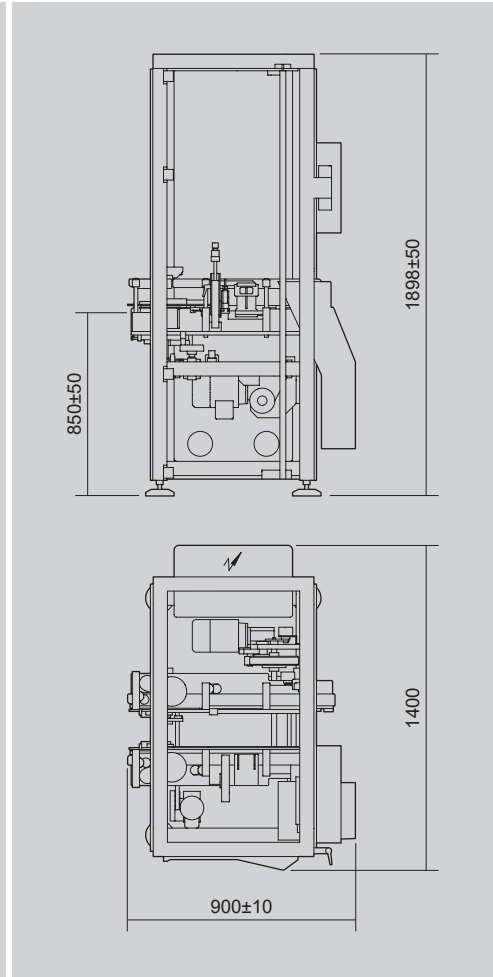

# TTS

## Tracking code application and reading machine



### TECHNICAL DATA

Mechanical speed	<b>STROKES/1'</b>	250
Motors	<b>KW</b>	2.5
Power absorption	<b>KW</b>	3.5
Air consumption	<b>NI/1'</b>	1
Air pressure	<b>bar</b>	5÷6
Gross weight	<b>kg</b>	~158
Net weight	<b>kg</b>	~150

Size range	TTS 1	min.	max.	TTS 2	min.	max.
<b>A</b>		25	85		25	110
<b>B</b>		20	70		20	70
<b>C</b>		70	200		70	200

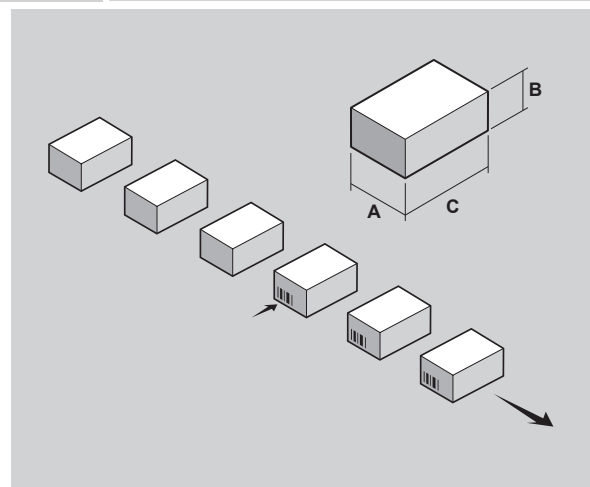

The technical data, the images and the diagrams are exclusively indicative and not binding, they might be modified without notice.

CM-012-uk (10/02/2018)  
Extr. from FM-TTS-04-uk (10/02/2018)

This publication supersedes and replaces any previous edition and revision. All rights reserved. No part of this publication may be reproduced, stored in a retrieval system or transmitted in any form or by any means, electronic, mechanical, photocopying, recording or otherwise, without permission of Tecnicam s.r.l. (Bologna - Italy).