

L60

Continuous motion liquid filling and capping monobloc

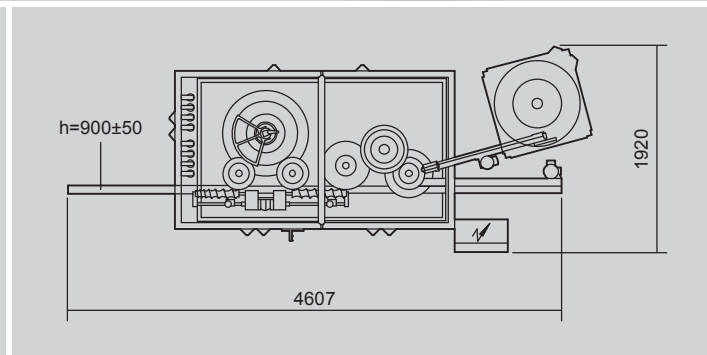
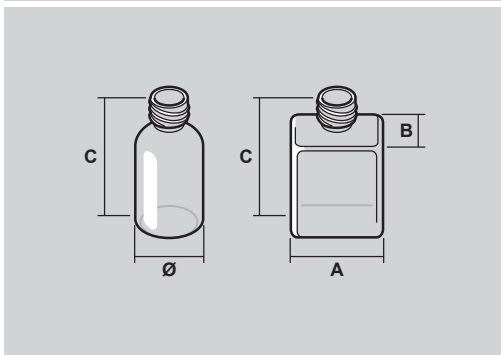

TECHNICAL DATA

Mechanical speed	STROKES/1'	200
Power absorption (max.)	KW	3.5
Air consumption	NI/1'	0 - 20
Air pressure	bar	5+6
Gross weight	kg	~1950
Net weight	kg	~1400
Size range	min.	max.
A	20	50
B	15	70
Ø	15	70
C	35	180

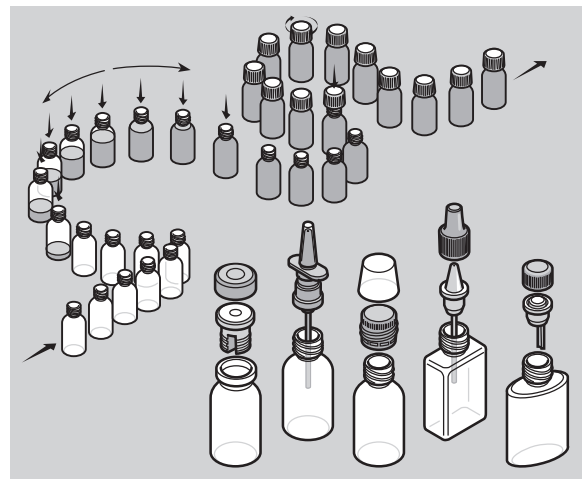

The above technical data are not binding and may be subject to change without prior notice.

CM-008-uk (12/11/2014)
Extr. from FM-L60-02-uk (10/11/2014)

This publication supersedes and replaces any previous edition and revision. All rights reserved. No part of this publication may be reproduced, stored in a retrieval system or transmitted in any form or by any means, electronic, mechanical, photocopying, recording or otherwise, without permission of Tecnicam s.r.l. (Bologna - Italy).