

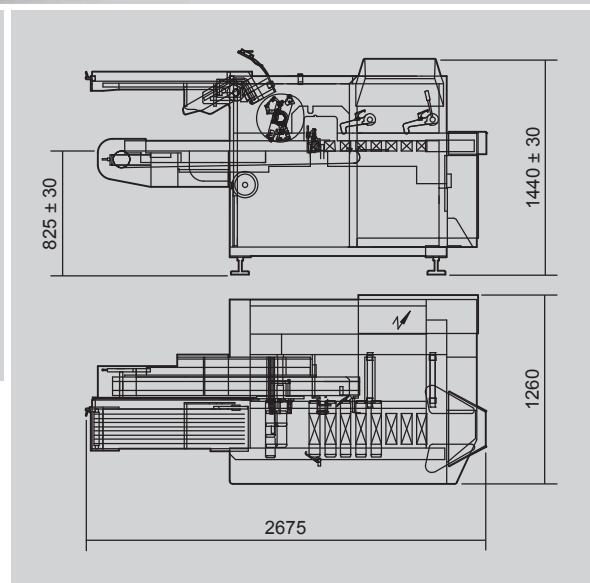

PMX

Intermittent motion horizontal cartoner

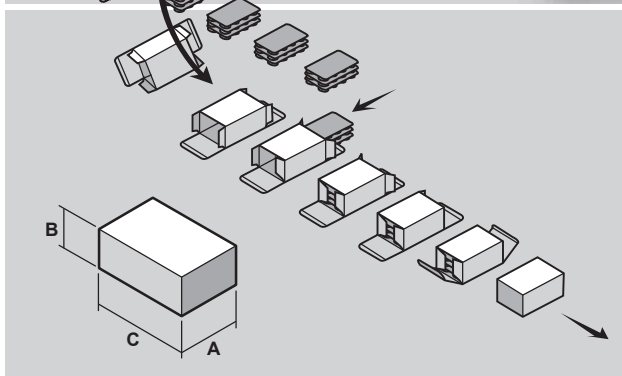

TECHNICAL DATA		PMX 1	PMX 2
Mechanical speed	STROKES/1'	25÷150	25÷110
Motors	KW	1.12	1.12
Power absorption	KW	1.75	1.75
		(Hot-melt + 3.9)	(Hot-melt + 3.9)
Air consumption	NI/1'	16.9	16.9
Air pressure	bar	5÷6	5÷6
Gross weight	kg	~1400	~1400
Net weight	kg	~1230	~1230

Size range	PMX 1 min.	PMX 1 max.	PMX 2 min.	PMX 2 max.
A	15	80	20	125
B	12	75	15	75
C	65	200	65	200
A + B	-	155	-	170

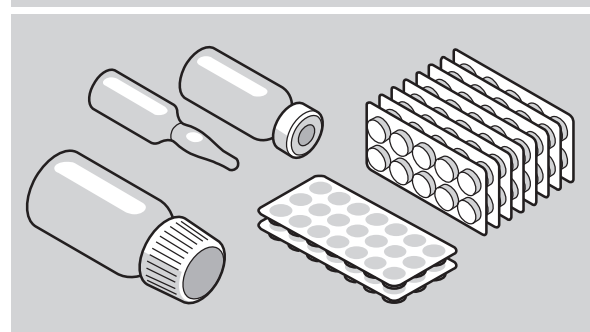

The above technical data are not binding and may be subject to change without prior notice.

CM-008-uk (12/11/2014)
Extr. from FM-PMX-02-uk (10/11/2014)

This publication supersedes and replaces any previous edition and revision. All rights reserved. No part of this publication may be reproduced, stored in a retrieval system or transmitted in any form or by any means, electronic, mechanical, photocopying, recording or otherwise, without permission of Tecnicam s.r.l. (Bologna - Italy).